

ORLEANE
CAMPUS A



ORLEANE
CAMPUS B



ATTITUDES



Linie ORLEANE
Feststehende Barriere

CAMPUS A

Lasiertes zertifiziertes Holz und lackierter, verzinkter Stahl.
Design J.M. Wilmotte

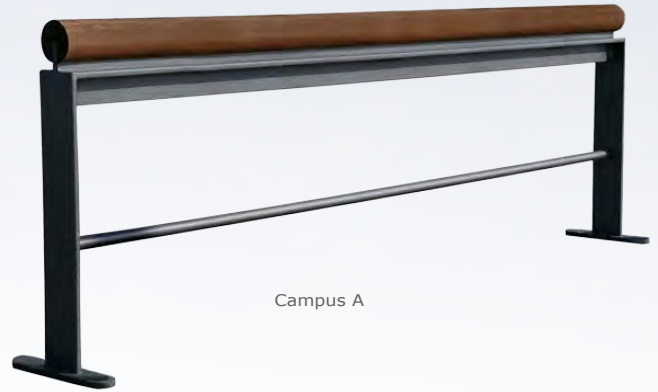
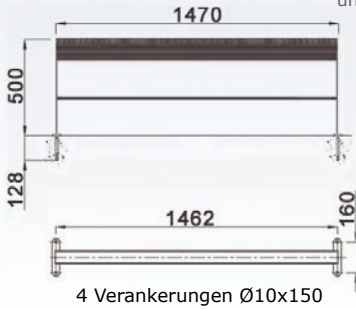

Campus A

CAMPUS B

Zertifiziertes, lasiertes Holz. Glattes Gestell aus lackiertem, verzinktem Stahl.
Design J.M. Wilmotte

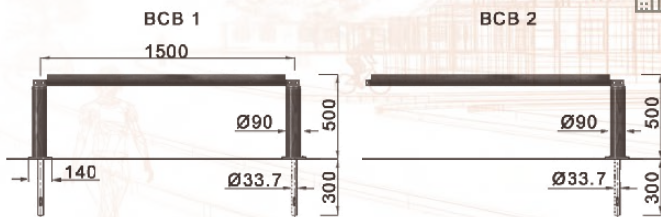

Campus B

ATTITUDES
Feststehende Barriere

Lasiertes, zertifiziertes Holz, metallisierter, lackierter Guss, Aluminium und verzinkter Stahl, lackiert.
Design Atelier Corajoud



Anpassstücke für die Reihen- oder Winkelmontage sind auf Anfrage hin erhältlich.





GHM Eclatec GmbH

LED Leuchten

Moderne Stadtmöbel

Abfalleimer

Licht Poller



BAUMGITTER

feststehende Poller

Klassische Gusseisen

Lichtsäulen

MODERNE GUSSEISEN

Trinkwasserbrunnen

Abwehripoller

LEITUNGSMASTEN

SITZGELEGENHEITEN

STRABENBAHN

Moderne LED-Leuchten

Zeitlose LED-Leuchten

Zeitlose Brunnen

Zeitlose Stadtmöbel

GHM Eclatec GmbH

Lebacher Straße 4 - 66113 Saarbrücken

Telefon Nr. 0781/9321800 - Telefax Nr. 0781/9321801

Email: info@ghm-eclatec.de - Seite: www.ghm-eclatec.de

Bankverbindung

Commerzbank Saarbrücken - Konto Nr. 530018100 - BLZ 590 400 00

IBAN DE79 5904 0000 0530 0181 00 - BIC COBADEFFXXX

HRB 102805 - Ust-IDNr. DE303737390